

Model 3200 Standard Stainless Steel Load Cell Compression Only

Why the Interface model 3200 Standard Stainless Steel Load Cell Compression Only is the best in class:

- Proprietary Interface temperature compensated strain gages
- Hermetically sealed cell
- Performance to .04%
- Compact size
- High 4mV/V output
- Eccentric load compensated
- .0008%/°F temp. effect on output
- Low deflection
- Shunt calibration
- Barometric compensation

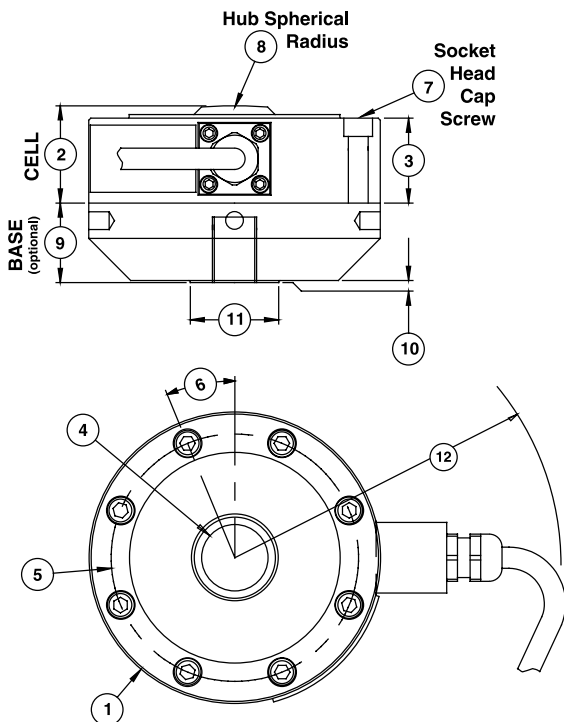

DIMENSIONS

See Drawing	3211		MODEL 3221		3231	
	2.5K, 5K, 10K		CAPACITY (lbf) 25K, 50K		100K	
	inch	mm	inch	mm	inch	mm
①	4.13	104.9	4.75	120.7	7.50	203.2
②	1.38	35.1	1.75	44.4	2.25	57.2
③	1.20	30.5	1.58	40.1	1.95	49.5
④	0.90	22.9	1.19	30.2	2.67	67.8
⑤	3.50	88.9	4.00	101.6	6.25	158.8
⑥	22.5°	22.5°	45.00°	45.0°	15.0°	15.0°
⑦	1/4-28 x 1 1/4		5/16-24 x 1 1/2		7/16-20 x 2	
	8 places		4 places		12 places	
⑧	6.00	152.40	6.00	152.40	8.00	203.20
⑨	1.13	28.70	1.25	31.80	2.00	50.80
⑩	0.03	00.80	0.03	00.80	0.03	00.80
⑪	1.25	31.80	2.00	50.80	3.00	76.20
⑫	4.80	121.90	5.61	142.50	5.30	134.60

SPECIFICATIONS

PARAMETERS	MODEL				
	3211	3211	3221	3221	3231
	CAPACITY (lbf)				
	2.5K, 5K	10K	25K	50K	100K
ACCURACY – (MAX ERROR)					
Static Error Band-% FS	± 0.04	± 0.04	± 0.04	± 0.04	± 0.04
Nonlinearity-% FS	± 0.05	± 0.05	± 0.05	± 0.05	± 0.05
Hysteresis-% FS	± 0.06	± 0.06	± 0.06	± 0.06	± 0.06
Nonrepeatability-% RO	± 0.01	± 0.01	± 0.01	± 0.01	± 0.01
Creep, 20 min-%	± 0.025	± 0.025	± 0.025	± 0.025	± 0.025
Side Load Sensitivity-%	± 0.25	± 0.25	± 0.25	± 0.25	± 0.25
Eccentric Load Sensitivity-%/in	± 0.25	± 0.25	± 0.25	± 0.25	± 0.25
TEMPERATURE					
Compensated Range-°F	15 to 115	15 to 115	15 to 115	15 to 115	15 to 115
Compensated Range-°C	-10 to 45	-10 to 45	-10 to 45	-10 to 45	-10 to 45
Operating Range-°F	-65 to 200	-65 to 200	-65 to 200	-65 to 200	-65 to 200
Operating Range-°C	-55 to 90	-55 to 90	-55 to 90	-55 to 90	-55 to 90
Effect on Zero-%RO/°F – MAX	± 0.0008	± 0.0008	± 0.0008	± 0.0008	± 0.0008
Effect on Output-%/°F – MAX	± 0.0008	± 0.0008	± 0.0008	± 0.0008	± 0.0008
ELECTRICAL					
	(2.5K 2.0)				
Rated Output-mV/V (Nominal)	4.0	4.0	4.0	4.0	4.0
Excitation Voltage-VDC MAX	20	20	20	20	20
Bridge Resistance-Ohm (Nominal)	350	350	350	350	350
Zero Balance-% RO	± 1.0	± 1.0	± 1.0	± 1.0	± 1.0
Insulation Resistance-Megohm	5000	5000	5000	5000	5000
MECHANICAL					
Safe Overload-% CAP	± 150	± 150	± 150	± 150	± 150
Deflection @ RO-inch	0.002	0.002	0.002	0.002	0.003
Optional Base-P/N	B302	B302	B306	B306	B304
Natural Frequency-kHz	6.1	8.6	8.2	11.7	7.6
Weight-lb	3.3	3.3	6.8	6.8	13.5
Calibration	Compression	Compression	Compression	Compression	Compression

OPTIONS* Page 115

- Base (Recommended)
- Submersible Cable
- Compression Overload Protection
- Cable length (20 ft Standard)
- Multiple Bridge
- Standardized Output
- See Transducer Electronic Data Sheet (TEDS) Page 118

ACCESSORIES* Page 119

- Instrumentation
- Load Button
- Top & Bottom Plates

*See appendix for more technical information

STANDARD CONFIGURATIONS

- Integral 20 ft Cable and Counterbored Mounting Holes (32xxBBE-nn)



Optional base