

INTERFACE CUSTOM DESIGNS

Interface Model MCC–Mini Compression-Only

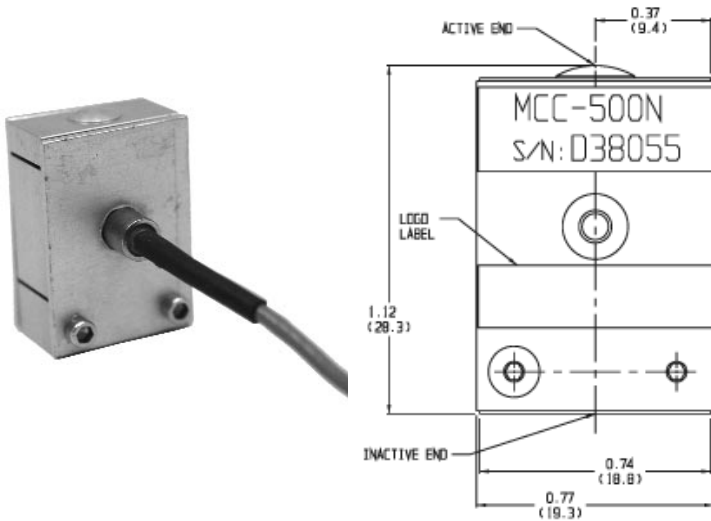

- Calibration application
- Test machine application
- Designed to fit in a machine that has tight space restrictions
- Capacity 500N

SPECIFICATIONS

Rated Output	2.2 mV/V
Nonlinearity %FS	±0.10
Hysteresis %FS	±0.10
Nonrepeatability %FS	±0.05

Interface Model 2120–Rod End

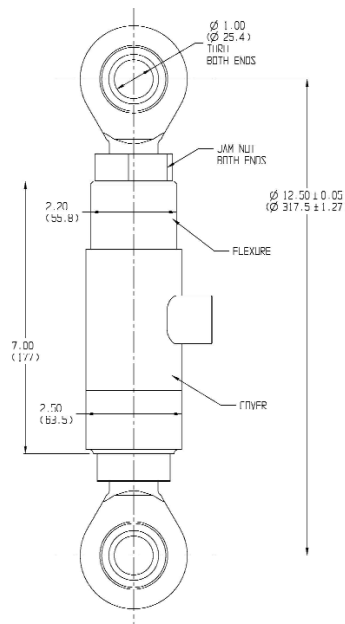

- Automotive application
- Used to measure forces in a shaker table
- Custom column style design with rod end bearings
- Capacity 200kN

SPECIFICATIONS

Rated Output	2 mV/V
Nonlinearity %FS	±0.25
Hysteresis %FS	±0.25
Nonrepeatability %FS	±0.05