

Model SPI Platform Scale Load Cell

Capacities 25-150 lbf



Why the Interface model SPI Platform Scale Load Cell is the best in class:

- Proprietary Interface temperature compensated strain gages
- .01% nonrepeatability
- Safe overload to 200%
- .0008%/°F temp. effect on output
- Eccentric load compensated

STANDARD CONFIGURATION

5 ft Integral Cable (SPI-nn)

OPTIONS

Extra Cable Length
Standardized Output

ACCESSORIES

Instrumentation

Consult factory for more technical information

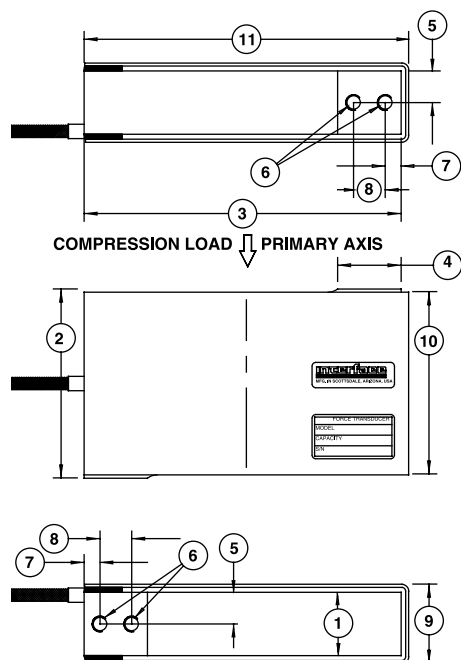

SPECIFICATIONS

ACCURACY – (MAX ERROR)

Nonlinearity–% FS	±0.02
Hysteresis–% FS	±0.02
Nonrepeatability–% RO	±0.01
Creep, in 20 min–%	±0.025
Eccentric load sensitivity–%/inch	0.002

TEMPERATURE

Compensated Range–°F	15 to 115
Compensated Range–°C	-10 to 45
Operating Range–°F	-65 to 200
Operating Range–°C	-55 to 90
Effect on Output–%/°F – MAX	±0.0008
Effect on Zero–% RO/°F – MAX	±0.0015

ELECTRICAL

Rated Output–mV/V (Nominal)	3.0
Zero Balance–% RO	±5.0
Bridge Resistance–Ohm (Nominal)	350
Excitation Voltage – MAX	15 VDC
Insulation Resistance–Megohm	5000

MECHANICAL

Calibration	Compression
Safe Overload–% CAP	200
Cable length–ft	5
Deflection @ RO–inch	to .008
Natural Frequency/Deflection:	

lbf	Deflection (inches)	Nat. Freq. (hertz)
25	.008	240
50	.008	310
100	.007	470
150	.005	580

DIMENSIONS

See Drawing	CAPACITY (lbf)			
	25, 50		100, 150	
	inch	mm	inch	mm
①	1.00	25.4	1.00	25.4
②	3.00	76.2	3.00	76.2
③	5.00	127	6.00	152.4
④	1.00	25.4	1.50	38.1
⑤	0.50	12.7	0.50	12.7
⑥	1/4-28 UNF-2B		1/4-28 UNF-2B	
⑥	0.56 in deep		0.56 in deep	
⑦	0.25	6.40	0.25	6.40
⑧	0.50	12.7	1.00	25.4
⑨	1.25	31.8	1.25	31.8
⑩	2.88	73.0	2.88	73.0
⑪	5.12	130	6.12	155.4